

# EWX12000U

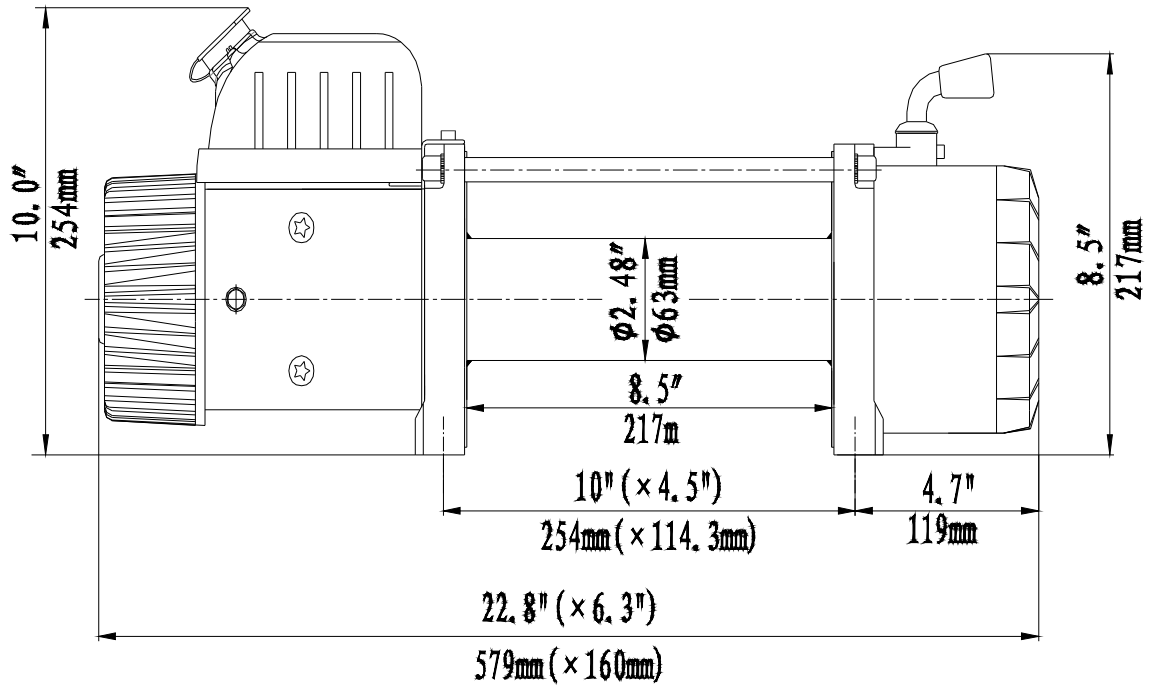

## SPECIFICATION (EWX12000U)

Rated line pull	12000 lbs (5443 kgs)
Motor: series wound	12V:Input: 5.4 kW / 7.2hp; Output: 2.7kW / 3.6hp 24V:Input: 5.3 kW / 7.1hp; Output: 3.3 kW /4.4hp
Gear reduction ratio	230:1
Cable (Dia. × L)	Ø7/16 " × 82 ' (Ø11mm × 25m)
Drum size (Dia. × L)	Ø2.48 " × 8.5 " (Ø63mm × 217mm)
Mounting bolt pattern	10 " × 4.5 " (254mm × 114.3 mm) 4-M10
Overall dimensions (L × W × H)	22.8" × 6.3" × 10.0" 579mm × 160mm × 254mm
Net weight lbs(kgs)	83.8 38

### Pull, Speed, Amperes, Volts (First layer):

Line Pull	Line Speed ft/min (m/min)		Current A	
	12V DC	24V DC	12V DC	24V DC
0(0)	22.3(6.8)	23.0(7.0)	100	60
4000(1814)	13.1(4.0)	13.8(4.2)	220	130
8000(3629)	9.8(3.0)	10.8(3.3)	330	170
12000(5443)	5.9(1.8)	7.5(2.3)	450	220

### Line Pull And Rope Capacity In Layer

Layer	Rated line pull lbs (kgs)	Total rope on the drum ft (m)
1	12000(5443)	14.8(4.5)
2	9563(4338)	32.8(10)
3	7948(3605)	57.4(17.5)
4	6800(3084)	82(25)